

DATA SHEET

**2.45 GHz ISM-band antenna for
Bluetooth and WLAN IEEE
802.11b**
Surface-mount ceramic
multilayer antennas

Product specification
Supersedes data of 27th September 2001

2002 Oct 17 Rev.2

Surface-mount ceramic multilayer antennas

2.45 GHz ISM-band antenna for Bluetooth and WLAN IEEE 802.11b

FEATURES

- Designed for 2.45 GHz ISM-band
- Simplifies antenna circuitry
- NiSn lead-free terminations
- Suitable for wave and reflow soldering
- Supplied in tape on reel.

APPLICATIONS

- Telecommunications
- Computing (PCs, printers, PDAs)
- Wireless office data communications including WLAN
- Consumer electronics (wireless headphones).

DESCRIPTION

This 2.45 GHz ceramic multilayer antenna has been designed to meet the requirements of the Bluetooth™⁽¹⁾ and IEEE 802.11b wireless communications protocol. It consists of a rectangular block of low-dielectric ceramic material and is fabricated in a water-based non-toxic process. The antenna is capable of providing good connectivity using near 50 Ω microstrip directly onto the PC board.

⁽¹⁾ Bluetooth is a trademark owned by Telefonieaktiebolaget L M Ericsson, Sweden.

ENVIRONMENTAL CARE



The foil making process uses an environment-friendly aqueous-solvent technology that fully complies with today's green-product design requirements. All terminations are lead-free. Packing materials can be recycled.

QUICK REFERENCE DATA

DESCRIPTION	VALUE
Centre frequency (for different central frequency shifts)	2.45, 2.60, 2.70, 2.80 and 2.90 GHz
Bandwidth	100 MHz
Gain	1.2 dBi max.
VSWR	2 max.
Polarization	Linear
Azimuth beamwidth	Omni-directional
Impedance	50 Ω
Power dissipation	1 W
Operating temperature	-55 to +125 °C
Terminations	NiSn
Resistance to soldering heat	260 °C for 10 s
Weight	0.16 g

Surface-mount ceramic multilayer antennas

2.45 GHz ISM-band antenna for Bluetooth and WLAN IEEE 802.11b

MECHANICAL DATA

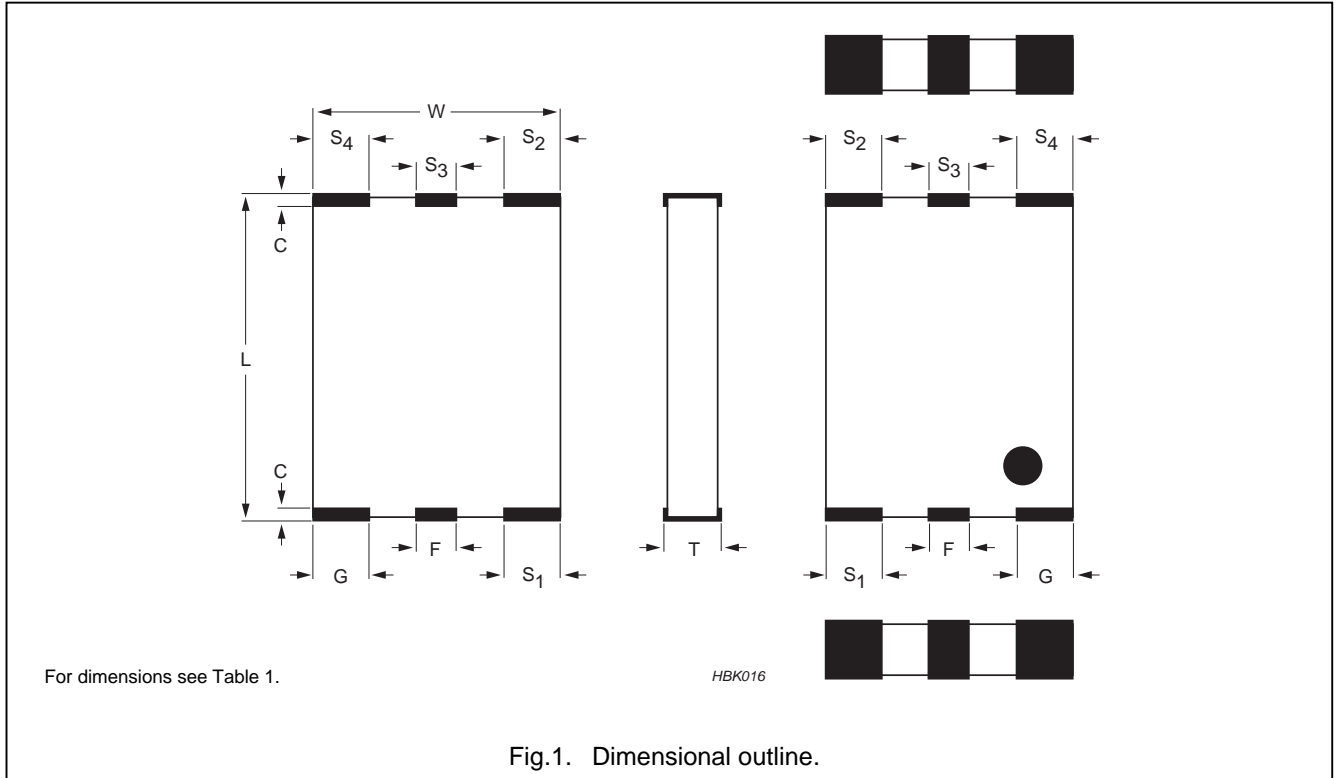

Physical dimensions

Table 1 Antenna dimensions

SYMBOL	DETAILS	DIMENSIONS (mm)
L	–	7.35 ±0.25
W	–	5.5 ±0.2
T	–	1.3 ±0.2
F	feed termination	0.9 ±0.25
G	optional ground termination ⁽¹⁾	1.25 ±0.35
C	–	0.5 ±0.3
S ₁	NC solder termination	1.25 ±0.35
S ₂	NC solder termination	1.25 ±0.35
S ₃	NC solder termination	0.9 ±0.25
S ₄	NC solder termination	1.25 ±0.35

Note

1. The antenna has built-in circuitry to the ground termination. Connecting the antenna's ground point to the system's RF ground plane is optional. If good matching is achieved, the ground termination is then used as a solder joint (like S₁, S₂, S₃, and S₄) to fix the antenna to the substrate only.

Device marking

CENTRE FREQUENCY (GHz)	MARKING CODE
2.45	no marking
2.60	6
2.70	7
2.80	8
2.90	9

Surface-mount ceramic multilayer antennas

2.45 GHz ISM-band antenna for Bluetooth and WLAN IEEE 802.11b

ELECTRICAL CHARACTERISTICS

DESCRIPTION	VALUE
Centre frequency	2.45, 2.60, 2.70, 2.80 and 2.90 GHz
Bandwidth	100 MHz
Gain	1.2 dBi max.
VSWR	2 max.
Polarization	Linear
Azimuth beamwidth	Omni-directional
Impedance	50 Ω
Power dissipation	1 W
Operating temperature	-55 to +125 °C
Terminations	NiSn
Resistance to soldering heat	260 °C, 10 sec.

FOOTPRINT DIMENSIONS

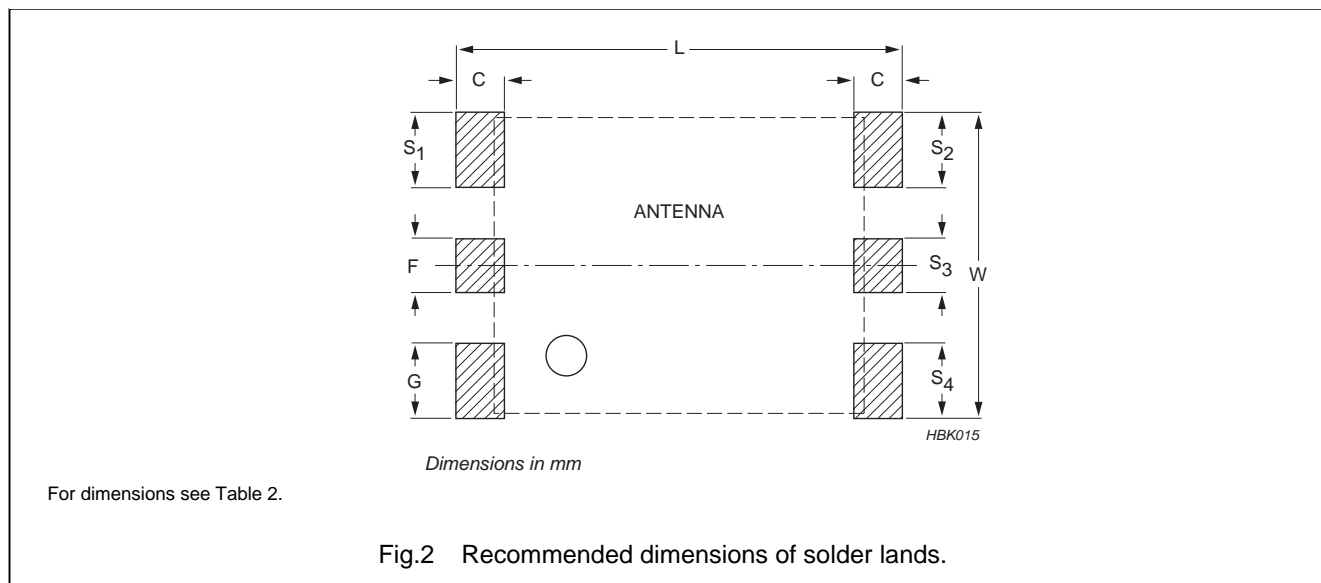

Physical dimensions

Table 2 Recommended solder land pattern

SYMBOL	COMMENT	DIMENSIONS (mm)	SYMBOL	COMMENT	DIMENSIONS (mm)
L	–	8.30 \pm 0.10	S ₁	NC mounting pad	1.40 \pm 0.10
W	–	5.70 \pm 0.10	S ₂	NC mounting pad	1.40 \pm 0.10
F	feed pad	1.00 \pm 0.10	S ₃	NC mounting pad	1.00 \pm 0.10
G	optional ground pad	1.40 \pm 0.10	S ₄	NC mounting pad	1.40 \pm 0.10
C	–	0.90 \pm 0.10	–	–	–

Surface-mount ceramic multilayer antennas

2.45 GHz ISM-band antenna for Bluetooth and WLAN IEEE 802.11b

STANDARD TEST BOARD FOR RADIATION PATTERN AND SWR MEASUREMENTS

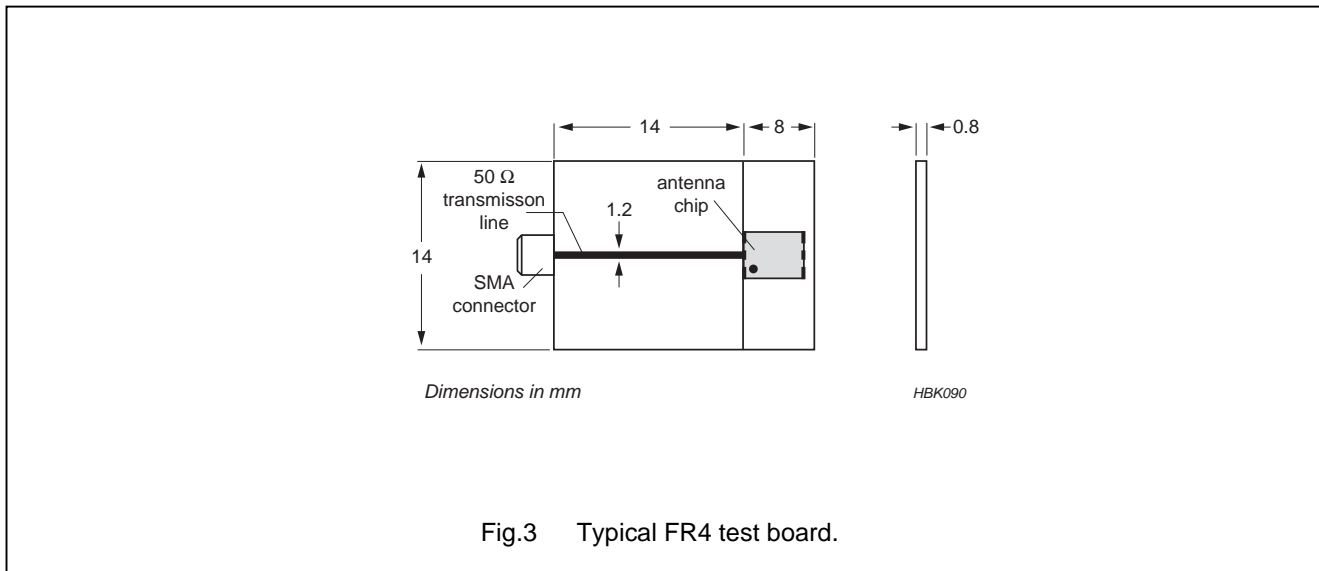

Fig.3 Typical FR4 test board.

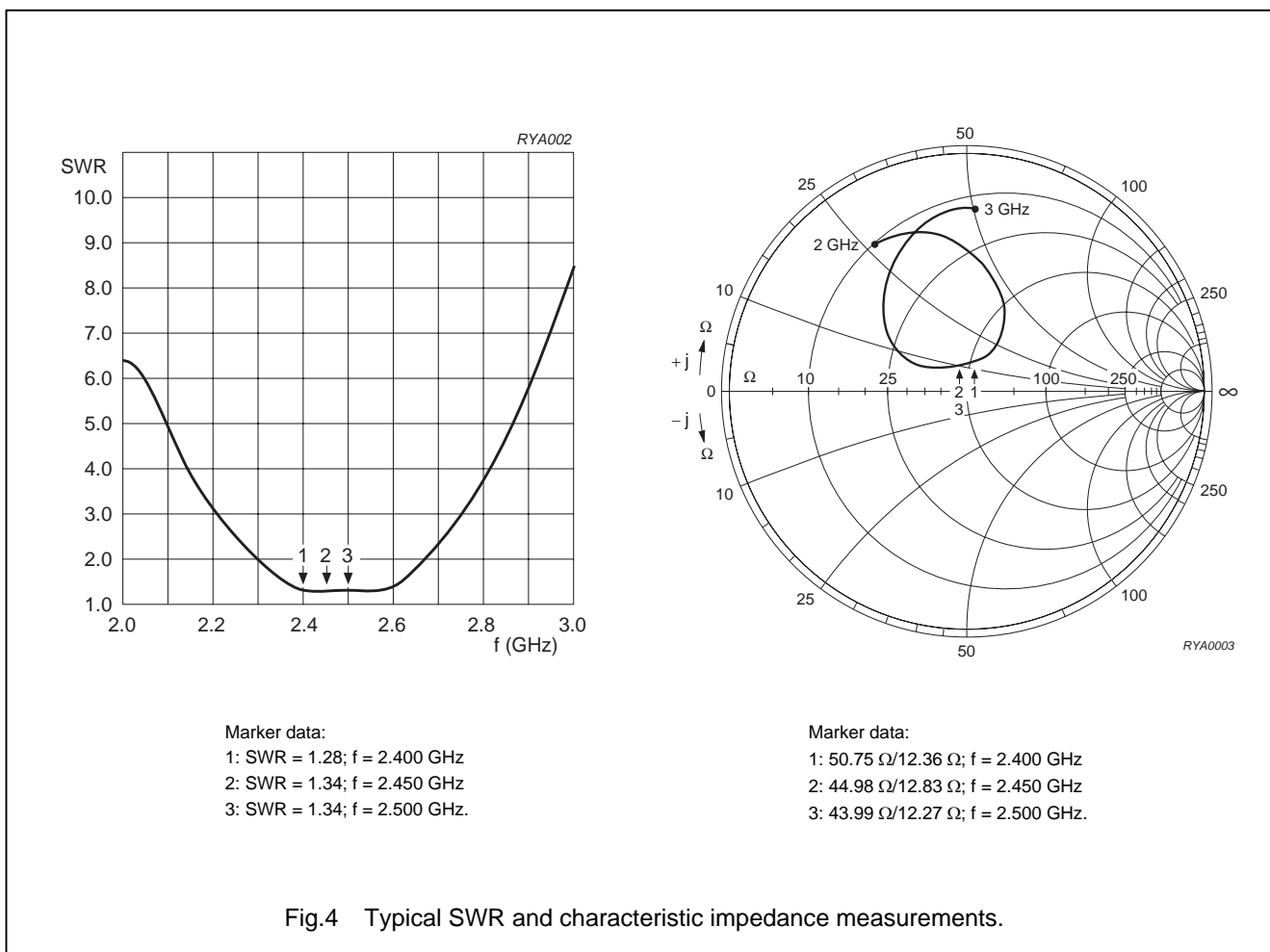

Fig.4 Typical SWR and characteristic impedance measurements.

Surface-mount ceramic multilayer antennas

2.45 GHz ISM-band antenna for Bluetooth and WLAN IEEE 802.11b

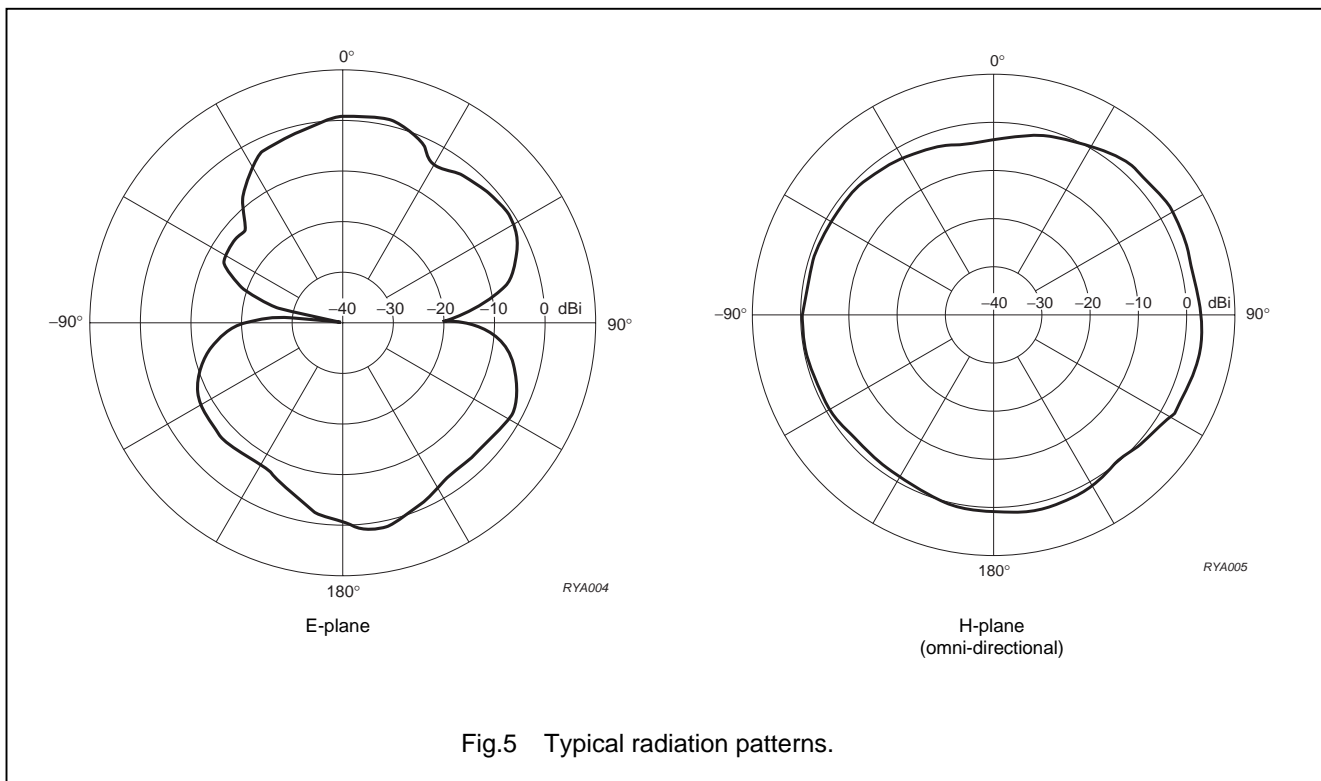
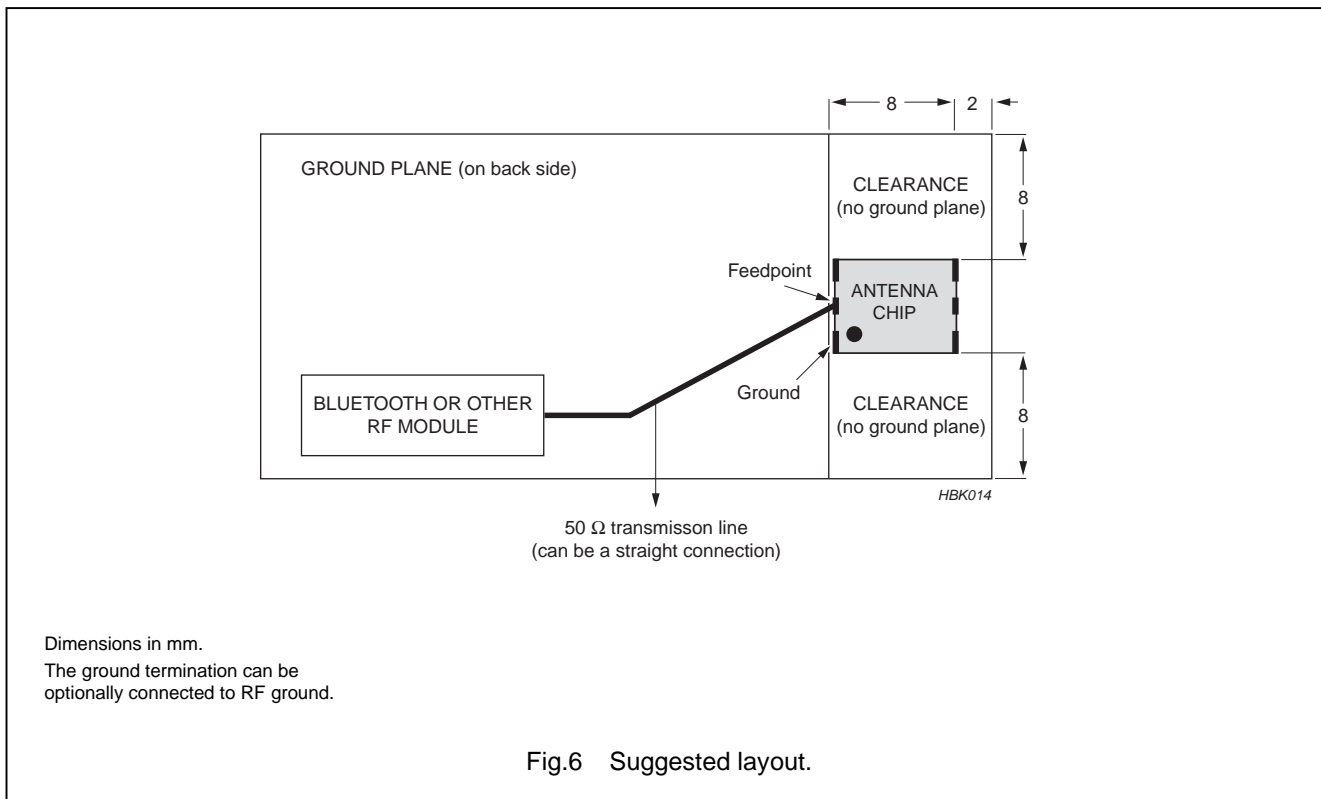

Fig.5 Typical radiation patterns.

APPLICATION EXAMPLE



Dimensions in mm.
The ground termination can be optionally connected to RF ground.

Fig.6 Suggested layout.

Surface-mount ceramic multilayer antennas

2.45 GHz ISM-band antenna for Bluetooth and WLAN IEEE 802.11b

ORDERING INFORMATION

Components may be ordered by using either a simple 15-digit clear text code or Phycomp's unique 12NC.

Ordering example for a Type 290 antenna, 1000 pieces supplied in blister tape on 180 mm reel.

Clear text code

EXAMPLE: AN2900000707051K

DESCRIPTION	CODE	ORDERING EXAMPLE
Product	AN = antenna type	AN
Centre frequency	2450 = 2.45 GHz 2800 = 2.80 GHz 2600 = 2.60 GHz 2900 = 2.90 GHz 2700 = 2.70 GHz	2900
Bandwidth	00 = 100 MHz	00
Material	07 = K7	07
Size	0705 = 7.35 × 5.5 × 1.3 mm	0705
Quantity	1 = 1000 pcs	1
Packing	K = 180 mm; 7" blister B = bulk case	K

12NC ordering code

EXAMPLE: 4311 111 00290 (TYPE 290 ANTENNA)

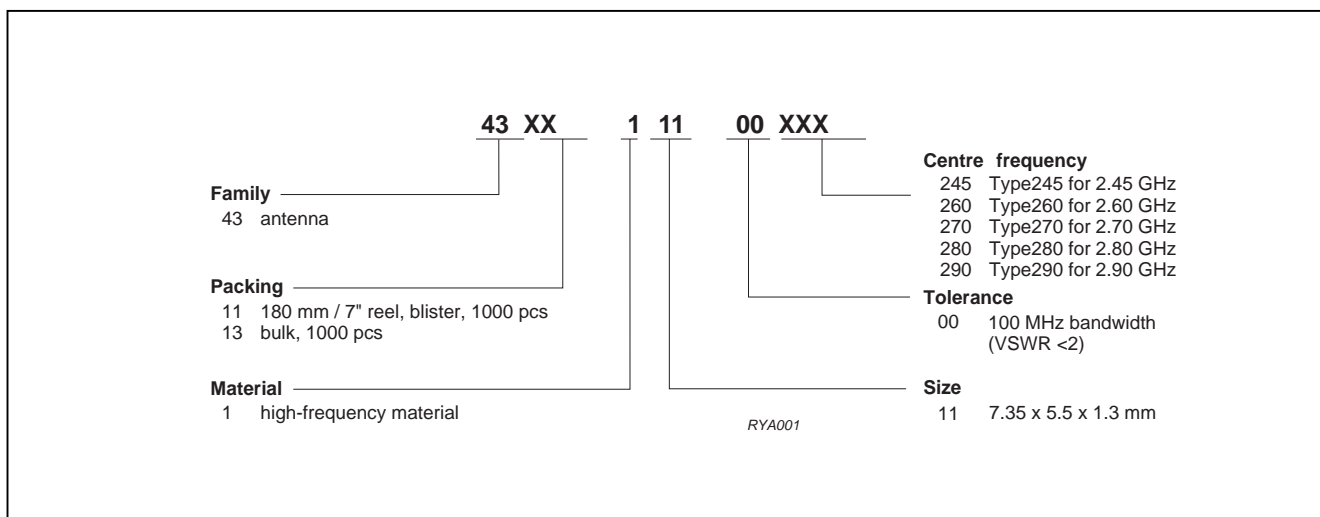

Surface-mount ceramic multilayer antennas

2.45 GHz ISM-band antenna for Bluetooth and WLAN IEEE 802.11b

TESTS AND REQUIREMENTS

Table 3 Test procedures and requirements

IEC 60384-10/ CECC 32 100 CLAUSE	IEC 60068-2 TEST METHOD	TEST	PROCEDURE	REQUIREMENTS
4.4		mounting	the antenna may be mounted on printed-circuit boards or ceramic substrates by applying wave soldering, reflow soldering (including vapour phase soldering) or conductive adhesive	no visible damage
4.5		visual inspection and dimension check	any applicable method using $\times 10$ magnification	no cracks or fissures larger than 4 mm
4.6.1		antenna	frequency: 2.45 GHz @ 20 °C	standard test board from Fig.3
4.8		adhesion	a force of 5 N applied for 10 s to the line joining the terminations and in a plane parallel to the substrate	no visible damage
4.9		bond strength of plating on end face	mounted in accordance with CECC 32 100, paragraph 4.4	no visible damage
			conditions: bending 1 mm at a rate of 1 mm/s; radius jig: 340 mm; 2 mm warp on FR4 board of 90 mm length	no visible damage
4.10	20 (Tb)	resistance to soldering heat	260 \pm 5 °C for 10 \pm 0.5 s in a static solder bath	the terminations shall be well tinned after recovery; centre frequency shift within $\pm 6\%$
		resistance to leaching	260 \pm 5 °C for 30 \pm 1 s in a static solder bath	using visual enlargement of $\times 10$, dissolution of the terminations shall not exceed 10%
4.11	20 (Ta)	solderability	zero hour test, and test after storage (20 to 24 months) in original packing in normal atmosphere; unmounted chips completely immersed for 2 \pm 0.5 s in a solder bath at 235 \pm 5 °C	the terminations must be well tinned for at least 75%

**Surface-mount ceramic
multilayer antennas**
**2.45 GHz ISM-band antenna for
Bluetooth and WLAN IEEE 802.11b**

IEC 60384-10/ CECC 32 100 CLAUSE	IEC 60068-2 TEST METHOD	TEST	PROCEDURE	REQUIREMENTS
4.12	4 (Na)	rapid change of temperature	-55 °C (30 minutes) to +125 °C (30 minutes); 5 cycles	no visual damage; centre frequency shift within $\pm 6\%$
4.14	3 (Ca)	damp heat	500 \pm 12 hours at 60 °C; 90 to 95% RH	no visual damage; 2 hours recovery; centre frequency shift within $\pm 6\%$
4.15		endurance	500 \pm 12 hours at 125 °C	no visual damage; 2 hours recovery; centre frequency shift within $\pm 6\%$

Surface-mount ceramic multilayer antennas

2.45 GHz ISM-band antenna for Bluetooth and WLAN IEEE 802.11b

PACKING

Tape and reel specifications

Tape and reel specifications are in accordance with "IEC 60286-3". Basic dimensions are given in Figs 7 and 8, and Tables 4 and 5.

Peel-off force

Peel-off force of the blister tape is in accordance with "IEC 60286-3"; that is, at a peel-off speed of 300 ± 10 mm/minute, 0.1 N to 1.3 N for 16 mm tape. The peel-off angle should be between 165° and 180° .

Blister tape specifications

Blister tape

ENVIRONMENTAL CONSIDERATIONS

- Cover tape, carrier tape and reel do not contain environmentally-harmful PVC materials.
- Because the carrier tape is made of polycarbonate, a homogeneous material (mono-plastic), it is ideally suited for recycling.
- Compared to other PVC-free materials polycarbonate shows excellent stiffness and very little deformation with temperature.

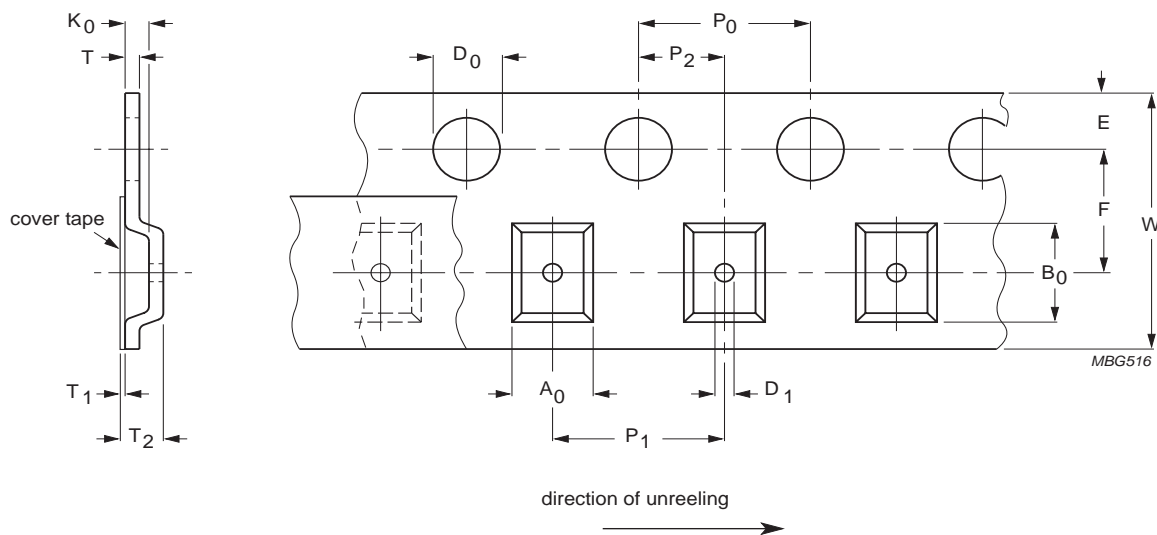

Cumulative pitch error: 0.2 mm over 10 pitches.

Cumulative tolerance over 10 holes: ± 0.2 mm.

K_0 : chosen so that the orientation of the component cannot change.

For dimensions see Table 4.

Fig.7 Blister tape.

Surface-mount ceramic multilayer antennas

2.45 GHz ISM-band antenna for Bluetooth and WLAN IEEE 802.11b

Table 4 Dimensions of blister tape; see Fig.7

SYMBOL	DIMENSION	TOLERANCE	UNIT
A ₀ nominal clearance; note 1	5.85	±0.10	mm
B ₀ nominal clearance; note 1	7.60	±0.10	mm
K ₀ minimum clearance; note 1	1.70	±0.10	mm
W	16.0	±0.3	mm
E	1.75	±0.10	mm
F	7.50	±0.10	mm
D ₀	1.55	±0.10	mm
D ₁	1.50	±0.10	mm
P ₀ ; note 2	4.0	±0.1	mm
P ₁	8.0	±0.1	mm
P ₂	2.0	±0.1	mm
T	0.30	±0.10	mm

Notes

1. Possible product displacement in pocket.
2. P₀ pitch tolerance over any 10 pitches is ±0.2 mm.

Surface-mount ceramic multilayer antennas

2.45 GHz ISM-band antenna for Bluetooth and WLAN IEEE 802.11b

Reel specifications

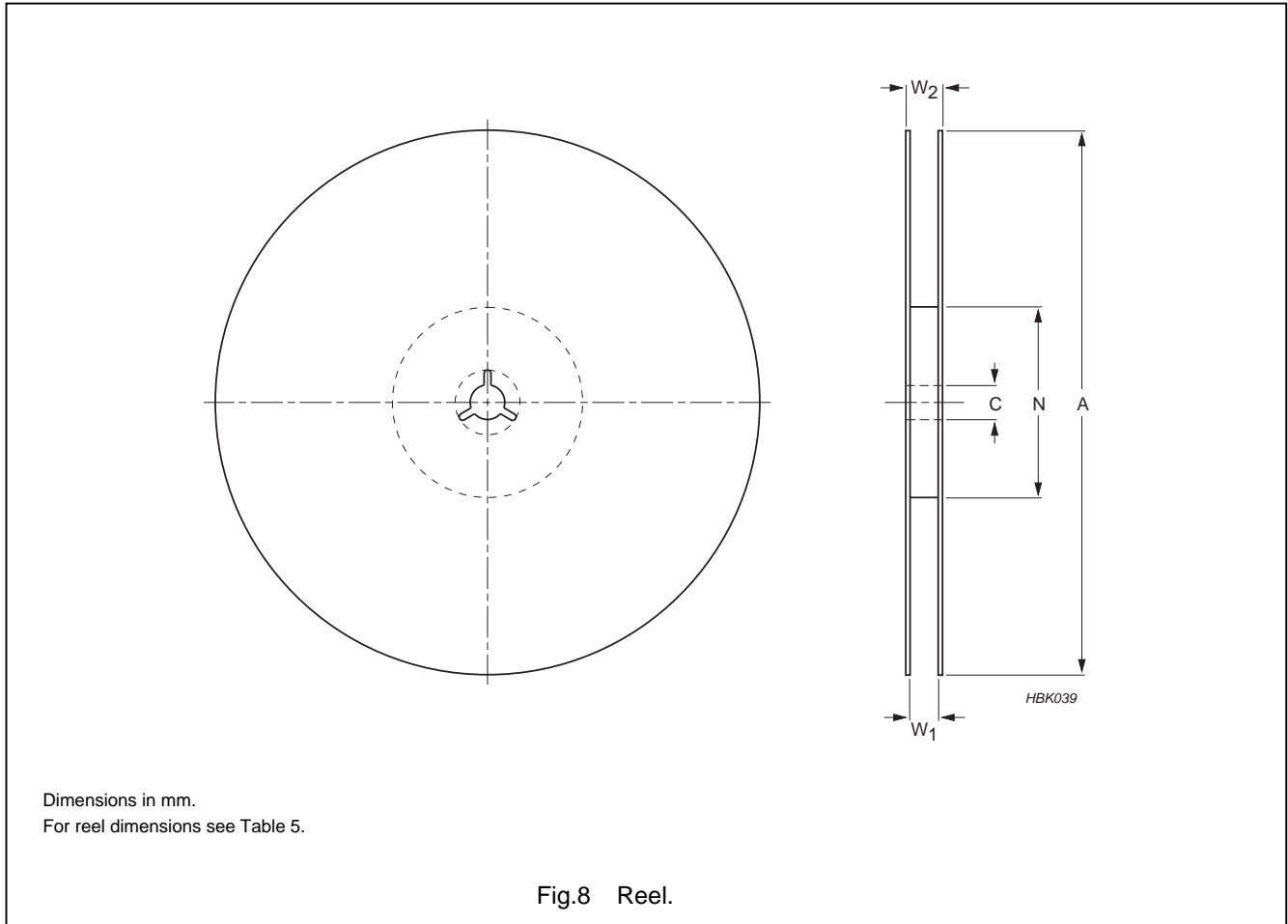

Table 5 Reel dimensions; see Fig.8

QUANTITY PER REEL	TAPE WIDTH (mm)	A (mm)	C (mm)	N (mm)	W ₁ (mm)	W ₂ (mm)
1000	16	180 ±0.1	13.0 ±0.5	62 ±0.5	16.0 +1/-0	20.5 ±0.2

**Surface-mount ceramic
multilayer antennas****2.45 GHz ISM-band antenna for
Bluetooth and WLAN IEEE 802.11b****REVISION HISTORY**

Revision	Date	Change Notification	Description
Rev.0	2001 Feb 06	–	- First issue of this specification.
Rev.1	2001 Sep 27	–	- Specification status changed from “Preliminary” to “Product specification” - Product range expanded with 2.60 and 2.70 GHz devices - Revised antenna dimensions (see Table 1) - 180 mm tape-and-reel and bulk packing options added - Blister tape-and-reel specifications added - Clear-text code ordering information added
Rev.2	2002 Oct 17	–	- Product range expanded with 2.80 and 2.90 GHz devices - Delete 4000 pcs packing - Reliability Test Items